



Fixture Type
Materials
Finish

Specialty Linear System
N/A
Silver

Lamp Type
Lamp Quantity
Lamp Included
Wattage
Input Voltage
Delivered Lumens
Kelvin Temperature
CRI
Power S Type
Power S Quantity
Power S Location
Dimming Type

LED
1
Yes
3.6 W
24 V
238 lm/ft
1800-2700K
90
Driver
Up to 2 fixtures
Remote
ELV

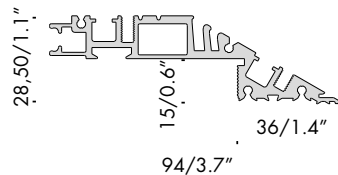

Designer:

Viabizzuno

Listings

ETL



per una buona esecuzione dei lavori nel cartongesso da 12,5mm/0.5" o 9,5mm/0.4" utilizzare sempre lo spessore compensatore f6.094.50
for good results when using 12.5mm/0.5" or 9.5mm/0.4" plasterboard, f6.094.50 thickness balancer should always be used.

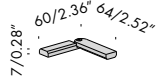
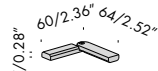
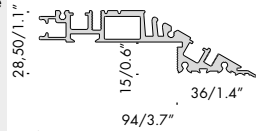
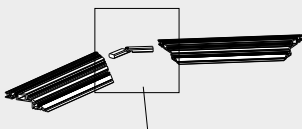
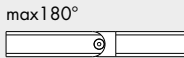
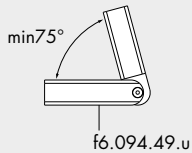
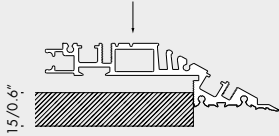

094 sistema h.15

Code	Material	Quantity	Length	Weight
f6.094.02	alluminio naturale natural aluminium	2 pz · pcs	500mm 19.7"	1,3kg 2.9lb
f6.094.02.n	nero55	2 pz · pcs	500mm 19.7"	1,3kg 2.9lb
f6.094.04	alluminio naturale natural aluminium	2 pz · pcs	1000mm 39.4"	2,5kg 5.5lb
f6.094.04.n	nero55	2 pz · pcs	1000mm 39.4"	2,5kg 5.5lb
f6.094.06	alluminio naturale natural aluminium	2 pz · pcs	2000mm 78.7"	5,0kg 11lb
f6.094.06.n	nero55	2 pz · pcs	2000mm 78.7"	5,0kg 11lb
f6.094.08	alluminio naturale natural aluminium	2 pz · pcs	3000mm 118.11"	7,6kg 16.8lb
f6.094.08.n	nero55	2 pz · pcs	3000mm 118.11"	7,6kg 16.8lb
f6.094.09.1	alluminio naturale natural aluminium	100 pz · pcs	3000mm 118.11"	412kg 908.3lb
f6.094.09.n.1	nero55	100 pz · pcs	3000mm 118.11"	412kg 908.3lb

accessori. accessories.

Code	Description	Quantity	Weight
f6.094.46	giunti lineari · linear joints	2 pz · pcs	0,02kg 0.04lb
f6.094.47.1	giunti lineari · linear joints	200 pz · pcs	1,8kg 4lb
f6.094.48	giunti angolari · angular joints		0,02kg 0.04lb
f9.001.62	giunti angolari · angular joints	4 pz · pcs	0,1kg 0.2lb
f6.094.49	giunto lineare snodato 094 sistema h.15 articulated angle joint		0,02kg 0.04lb
f6.094.49.u	giunto lineare snodato 094 sistema h.18 articulated angle joint		0,02kg 0.04lb

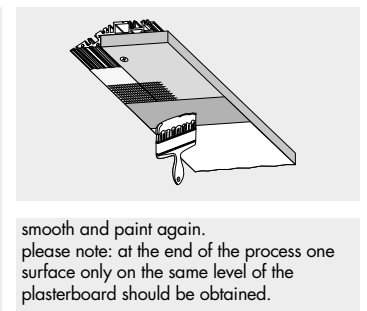
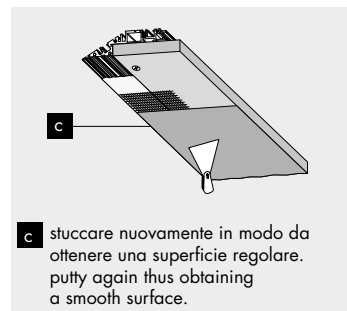
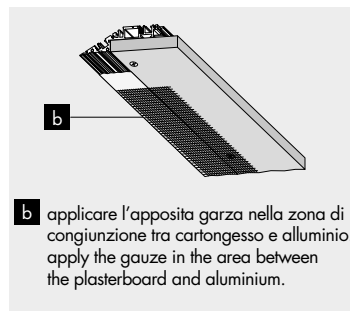
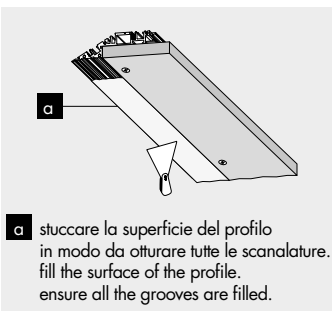



FEATURES

- Customizable
- Durable, anodized aluminum
- Protects LED systems from dust and other elements
- Slim, low profile design
- Dissipates heat from LED, prolonging its lifetime

SPECIFICATIONS

TYPE	Surface mount
AVAILABLE LENGTHS	49.25", 84" and 98.5"
FINISH	Silver / Black / White
LENS OPTIONS	Frosted
CHANNEL	ALP-60
LENS	ALP-60-LN
END CAP	ALP-60-EC
MOUNTING CLIPS	ALP-60-CL
ADJUSTABLE BRACKET (TALL)	ALP-60-BKT-ADJ
ADJUSTABLE BRACKET	ALP-60-ASB
WEIGHT	5.33 lbs
	Compatible with LED strips up to 12mm (0.48") wide.

LED tape light sold separately.

Frosted Lens diffuser included with every profile

2 (two) end caps included with every channel.

Custom color finishes available (powder-coating).

98" profile NOT available in black

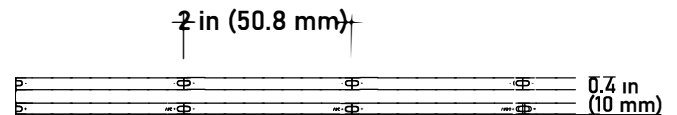
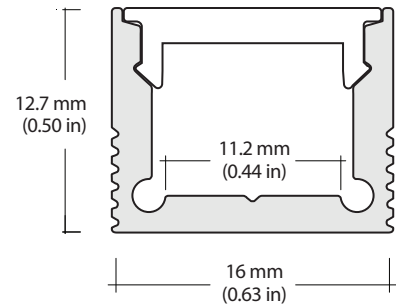

STANDARD ORDERING CODE

Model	Length	Lens	Light Engine	Finish
ALP60	49 49.25"	FR Frosted	See P.3	SI Silver
	84 84"			WH White
	98 98.5"			BK Black
				CU Custom (powder-coat)



NOTE: Custom color finishes require powder coating. Allow 7 days lead time.

98" profile NOT available in black



COMPONENTS AND ACCESSORIES

ALP-60 | Aluminum Profile

MOUNTING LENGTHS Surface
49.25" and 98.5"

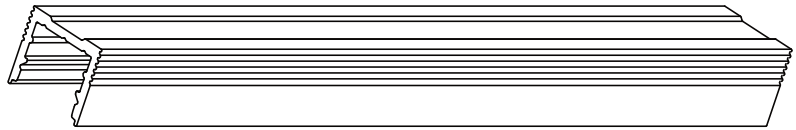

ALP-60LN | Lens Cover

TYPE Frosted (included)
LENGTHS 49.25" and 98.5"

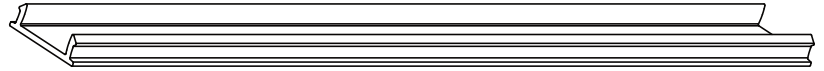

ALP-60EC | End Cap

Two end caps included with every profile

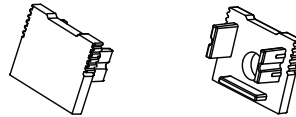

ALP-60CL | Metal Mounting Clips

Two end caps included with every profile

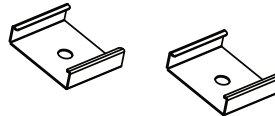

ALP-60-BKT-ADJ | Adjustable Bracket

* optional item (sold separately)

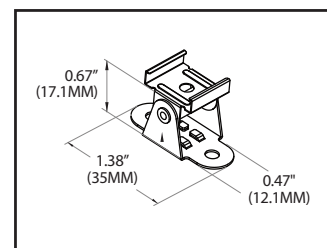
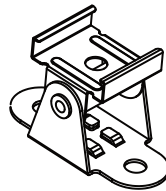

ALP-60-ASB | Adjustable Bracket

* optional item (sold separately)

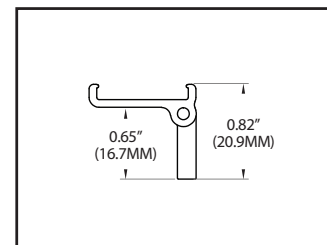
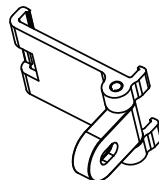

SPECIFICATIONS

INPUT VOLTAGE	24V DC
POWER CONSUMPTION	3.2 per foot
LUMEN OUTPUT	(27K) 272 Lm/Ft. (30K) 292 Lm/Ft. (40K) 297 Lm/Ft.
BEAM ANGLE	180°
CRI	90+
DIMMING	MLV, ELV, 0-10 and TRIAC
MAXIMUM RUN LENGTH	16.4 Feet
FIELD CUTTABLE	Every 2 in
IP RATING	IP54 dry location (indoor)
LUMEN MAINTENANCE	50,000 hrs.
OPERATING TEMPERATURE	-40°F(-40°C)~+140°F(+60°C)
BINNING	2 Step Macadam Elipse
CERTIFICATIONS	UL listed, TITLE 24 JA8
DIMENSIONS	0.4" x 0.08 (width x height)
WARRANTY	5 Years

Delivering a solid stream of linear light, the LSM32CB features the latest in COB technology for total linear diffusion in a low profile package. Fits profiles up to 0.4" (10mm) wide.

FEATURES

- 3.2W per Foot
- 90+ CRI
- California TITLE 24 JA8 compliant
- Field cuttable
- Suitable for accent or ambient lighting
- 27K, 30K and 40K CCT options available
- Available in 24V
- UL Listed
- Dimmable with CORE Lighting dimmable drivers

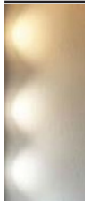
	COLOR TEMP	CRI	LUMEN/FT
	2700K	90	272
	3000K	90	292
	4000K	90	297



STANDARD ORDERING CODE

Model	Color Temp	Length	Voltage	Profile
LSM-32CB	27K 2700K	16 16.4 Ft.	24 24 Volts	²See p3 for options
	30K 3000K	100 100 Ft.		
	40K 4000K	¹XX per Ft.		

