



Fixture Type
Materials
Finish

Exterior wall
Bronze
Polished

Lamp Type
Lamp Quantity
Lamp Included
Wattage
Input Voltage
Delivered Lumens
Kelvin
CRI
Power S Type
Power S Quantity
Power S Location
Dimming Type

E12 LED
1
No
3.3W
110-120V
250
2700 K
+90
Driver
1
Integrated
Dependant

Designer

Henry Wilson

Listings

UL
DAMP

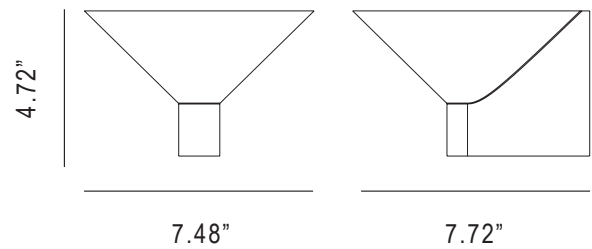

CONICAL WALL LIGHT



MATERIALS

I. METAL



Bronze



Blackened



Stainless Steel

WEIGHT

Bronze / Blackened
(2,500G / 88.2oz)

Stainless Steel
(2,500G / 88.2oz)

PACKAGING

Recycled Cardboard
H 125MM x L 200MM x W 200MM

CLEANING INSTRUCTIONS

Before cleaning, lighting fixtures must be turned off and unplugged from mains electricity. Whilst cleaning please take care and use the gloves provided.

I. METAL

The metal used for our range oxidise with age and environment, both of which contribute to the evolution of a natural patina. If you favour the original bright finish of your pieces, this is easily restored by use of polishing solution - we recommend Braso or Silvo depending on the metal in question - applied with a soft, clean cloth.

Because each object is cast in small batches, slight variations will occur from one individual piece to another. Production marks may include slight pour ripples or surface pitting, which imprint every item with a unique character.

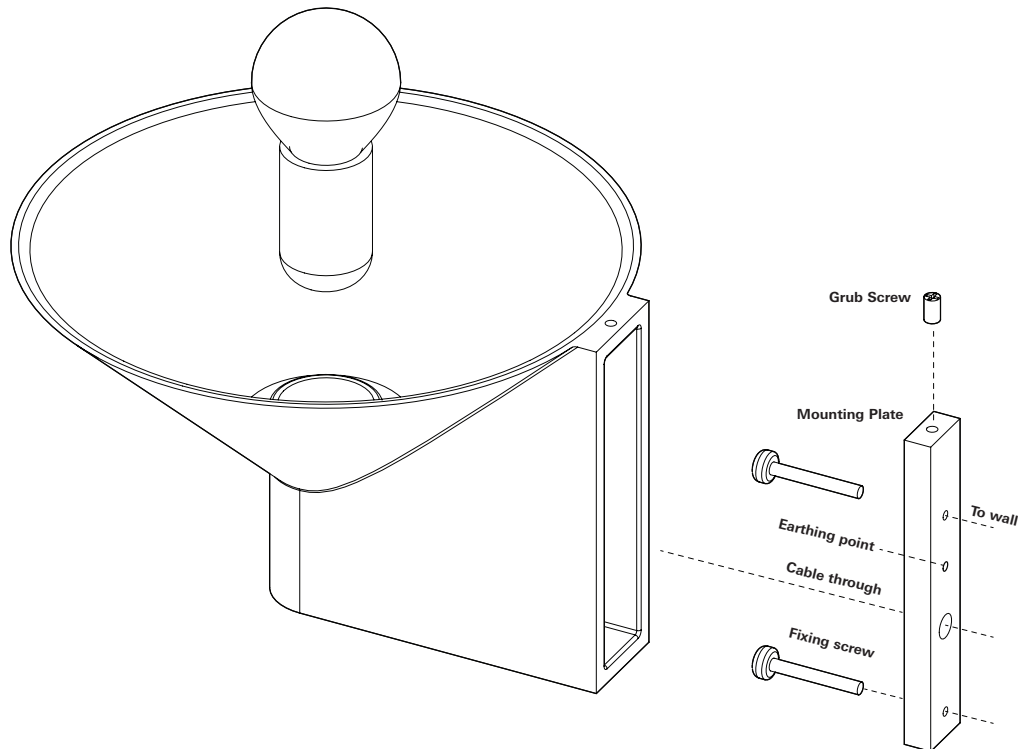

US / JPN

LIGHTBULB TYPE
9W LED max (not supplied)

FITTING DESCRIPTION
Edison Ø12MM (E12)

SUGGESTED LUMEN RATING
250LM

WATTAGE
3.3w Equiv 25w Incandescent

KELVIN RATING
2700k-3000k Warm White

VOLTAGE
110-120v / 60HZ AC

DIMMABILITY
Bulb dependant

HS CODE LAMPS / LIGHT FITTINGS
9405.40.8440

HS CODE CORD SETS / POWER SUPPLY
ELBZ.E465216

LISTED PARTS *
UL Lamp Holder E3810

UL Cord ELBZ . E465216

Canda ELBZ . E465216

**IF THE SUPPLIED CORD IS DAMAGED,
REPLACE WITH 2 CORE SHEATHED TYPE
ONLY. HARDWIRED LAMPS MUST BE
INSTALED BY A PROFESSIONAL.**

